

ArcGlide[®] THC Replacement Parts

Field Service Bulletin

806560 Revision 3 November 2013

Hypertherm[®]

Hypertherm, Inc.

Etna Road, P.O. Box 5010

Hanover, NH 03755 USA

603-643-3441 Tel (Main Office)

603-643-5352 Fax (All Departments)

info@hypertherm.com (Main Office Email)

800-643-9878 Tel (Technical Service)

technical.service@hypertherm.com (Technical Service Email)

800-737-2978 Tel (Customer Service)

customer.service@hypertherm.com (Customer Service Email)

866-643-7711 Tel (Return Materials Authorization)

877-371-2876 Fax (Return Materials Authorization)

return.materials@hypertherm.com (RMA email)

Hypertherm Plasmatechnik GmbH

Technologiepark Hanau

Rodenbacher Chaussee 6

D-63457 Hanau-Wolfgang, Deutschland

49 6181 58 2100 Tel

49 6181 58 2134 Fax

49 6181 58 2123 (Technical Service)

Hypertherm (S) Pte Ltd.

82 Genting Lane

Media Centre

Annexe Block #A01-01

Singapore 349567, Republic of Singapore

65 6841 2489 Tel

65 6841 2490 Fax

65 6841 2489 (Technical Service)

Hypertherm (Shanghai) Trading Co., Ltd.

Unit 301, South Building

495 ShangZhong Road

Shanghai, 200231

PR China

86-21-60740003 Tel

86-21-60740393 Fax

Hypertherm Europe B.V.

Vaartveld 9

4704 SE

Roosendaal, Nederland

31 165 596907 Tel

31 165 596901 Fax

31 165 596908 Tel (Marketing)

31 165 596900 Tel (Technical Service)

00 800 4973 7843 Tel (Technical Service)

Hypertherm Japan Ltd.

Level 9, Edobori Center Building

2-1-1 Edobori, Nishi-ku

Osaka 550-0002 Japan

81 6 6225 1183 Tel

81 6 6225 1184 Fax

Hypertherm Brasil Ltda.

Rua Bras Cubas, 231 – Jardim Maia

Guarulhos, SP - Brasil

CEP 07115-030

55 11 2409 2636 Tel

55 11 2408 0462 Fax

Hypertherm México, S.A. de C.V.

Avenida Toluca No. 444, Anexo 1,

Colonia Olivar de los Padres

Delegación Álvaro Obregón

México, D.F. C.P. 01780

52 55 5681 8109 Tel

52 55 5683 2127 Fax

Hypertherm Korea Branch

#3904 Centum Leaders Mark B/D,

1514 Woo-dong, Haeundae-gu, Busan

Korea, 612-889

82 51 747 0358 Tel

82 51 701 0358 Fax



| | | |
|----------|--|-----------|
| 1 | Parts | 5 |
| | Introduction | 5 |
| | Tools | 5 |
| | Lifter parts | 6 |
| | THC controller parts | 8 |
| | HMI parts | 9 |
| | Plasma interface board | 10 |
| 2 | Replacing ArcGlide parts | 11 |
| | Accessing ArcGlide parts | 12 |
| | Accessing lifter parts | 12 |
| | Accessing control module parts | 12 |
| | Accessing HMI parts | 12 |
| | Replacement procedures | 13 |
| | 228576 – Plasma interface board | 13 |
| | 228577 – THC control interface board | 14 |
| | 228578 – THC processor board | 15 |
| | 228579 – 230 V surge board | 16 |
| | 228580 – Lifter interface board | 17 |
| | 228581 – HMI processor board | 18 |
| | 228582 – HMI 7-segment display board | 19 |
| | 228583 – Momentary pushbutton switch | 20 |
| | 228584 – Torch up/down switch | 21 |
| | 228585 – Enable/disable switch | 22 |
| | 228586 – Lifter lower limit proximity switch | 23 |
| | 228587 – Lifter upper limit proximity switch | 25 |
| | 228588 – Station Enable 5 V LED | 26 |
| | 228589 – LCD display | 27 |

Contents

| | |
|---|----|
| 228590 – 120 VAC, 5 V, 5 amp, 25 W power source | 28 |
| 228591 – Lifter slide | 29 |
| 228592 – Laser pointer diode | 29 |
| 228593 – 11.34 kg (25 lb) Magnetic breakaway | 30 |
| 228607 – 4.54 kg (10 lb) Magnetic breakaway | 30 |
| 228595 – Lifter motor brushes | 31 |
| 228597 – Pneumatic breakaway | 31 |
| 228608 – Breakaway cable | 32 |
| 228938 – 20 kf (45 lbf) Replacement magnets | 35 |
| 228939 – 35.7 kf (78.7 lbf) Replacement magnets | 35 |
| 228940 – Breakaway retaining tether | 36 |
| 428081 – Servo amplifier module | 36 |
| 428241 – Lifter side shield | 38 |
| 428242 – Ohmic wire | 38 |
| 428245 – Sealing band | 40 |
| 428302 – Lifter motor | 40 |

Section 1

Parts

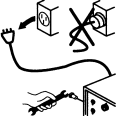
| | | |
|--|---|--|
|  |  | WARNING! ELECTRIC SHOCK CAN KILL |
|  | | Disconnect electrical power before performing any maintenance. See the <i>Safety</i> section of the <i>ArcGlide THC Instruction Manual</i> for more safety precautions. |

Introduction

This Field Service Bulletin provides information on replacement parts for the ArcGlide THC and how to replace them.

Tools

The following tools and materials are used in the replacement procedures in this FSB:

- 9/16-inch wrench
- 1/4-inch socket wrench and extension
- 14 mm, 21 mm wrenches
- Hex wrenches (inches): 3/32, 7/64, 9/64, 5/32, 3/16, 0.05
- Hex wrenches (metric): 3 mm, 4 mm
- Adjustable wrench
- 3/16-inch blade screwdriver
- Number 1 and 2 Phillips screwdrivers
- Needle-nose pliers
- Thread sealant (Loctite® 242 or equivalent)
- Level

1 – Parts

Lifter parts

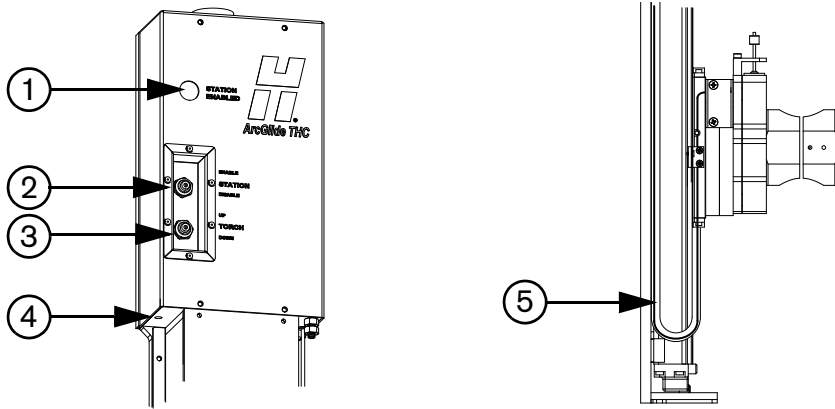

| Item | Kit number | Description | Quantity |
|------|------------|--|----------|
| 1 | 228588 | Station Enable 5 V LED | 1 |
| 2 | 228585 | Enable/disable switch | 1 |
| 3 | 228584 | Torch up/down switch | 1 |
| 4 | 228592 | Laser pointer diode | 1 |
| 5 | 228608 | Breakaway cable | 1 |
| 6 | 228593 | 11.34 kg (25 lb) magnetic breakaway | 1 |
| 7 | 228607 | 4.54 kg (10 lb) magnetic breakaway | 1 |
| 8 | 228597 | Pneumatic breakaway | 1 |
| 9 | 228939 | 35.7 kf (78.7 lbf) replacement magnets | 4 |
| | 104473 | 35.7 kf (78.7 lbf) replacement magnet | 1 |
| 10 | 228938 | 20 kf (45 lbf) replacement magnets | 5 |
| | 104513 | 20 kf (45 lbf) replacement magnet | 1 |
| 11 | 228940 | Breakaway retaining tether | 1 |

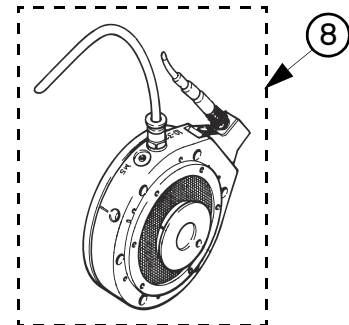
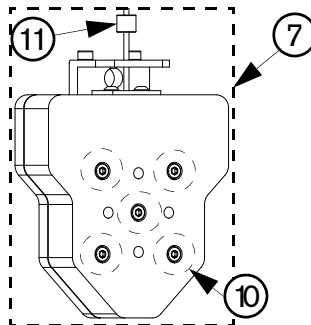
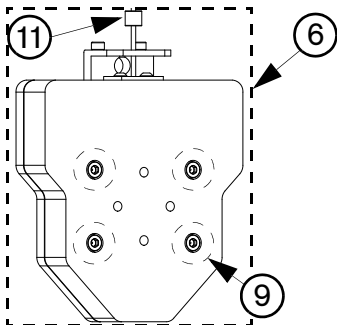

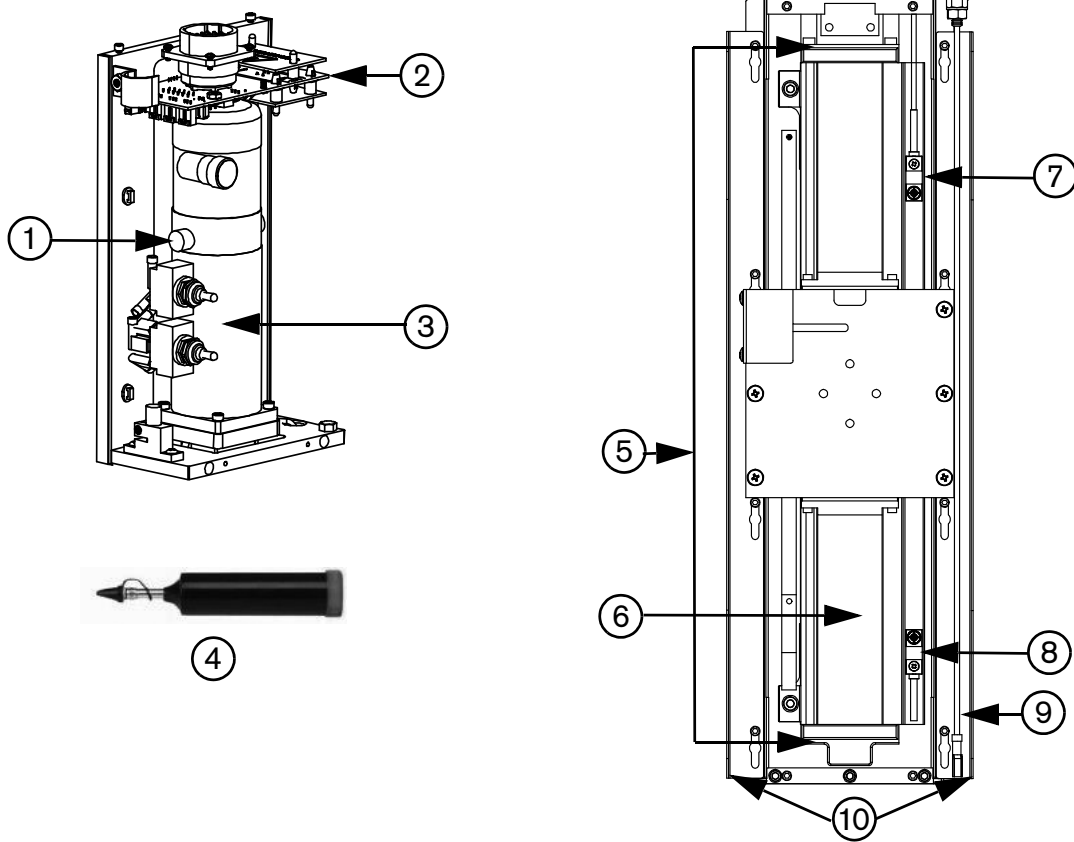

| Item | Kit number | Description | Quantity |
|------|------------|-------------------------------------|----------|
| 1 | 228595 | Lifter motor brushes | 2 |
| 2 | 228580 | Lifter interface board | 1 |
| 3 | 428302 | Lifter motor | 1 |
| 4 | 428259 | Grease gun | 1 |
| 5 | 228591 | Lifter slide | 1 |
| 6 | 428245 | Sealing band | 1 |
| 7 | 228587 | Lifter upper limit proximity switch | 1 |
| 8 | 228586 | Lifter lower limit proximity switch | 1 |
| 9 | 428242 | Ohmic wire | 1 |
| 10 | 428241 | Lifter side shields | 2 |

THC controller parts

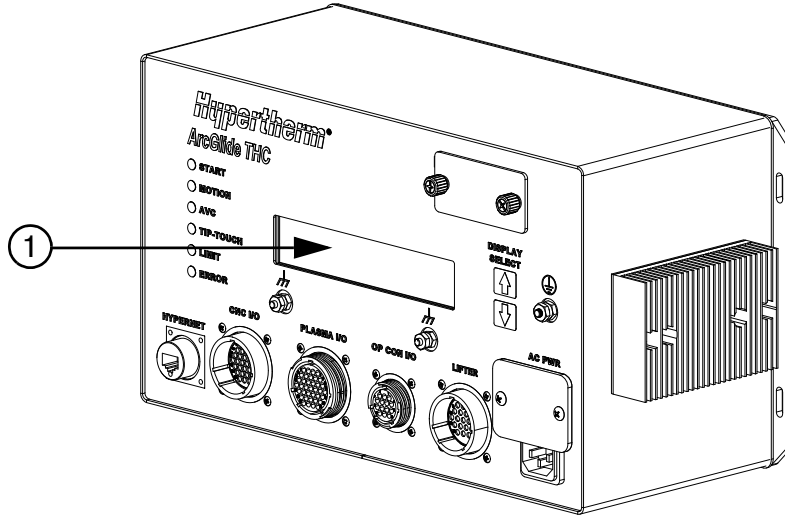

| Item | Kit number | Description | Quantity |
|------|------------|--|----------|
| 1 | 228589 | LCD display | 1 |
| 2 | 228578 | THC processor board | 1 |
| 3 | 428081 | Servo amplifier module | 1 |
| 4 | 228577 | THC control interface board | 1 |
| 5 | 228579 | 230 V surge board | 1 |
| 6 | 228590 | 120 VAC, 5 V, 5 amp, 25 W power source | 1 |

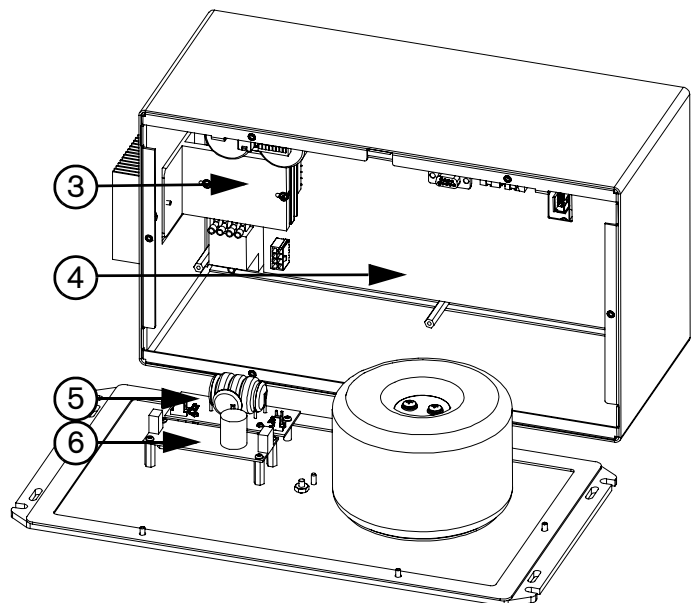
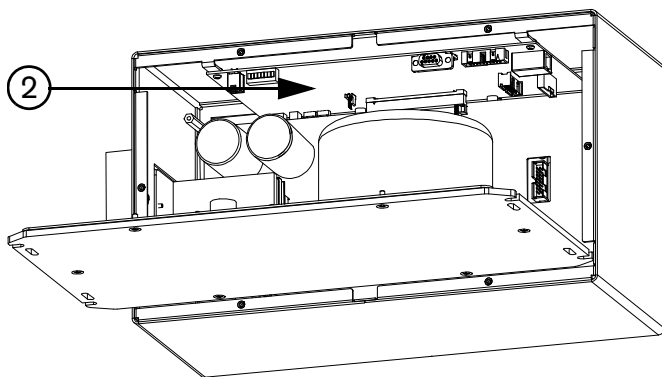

HMI parts

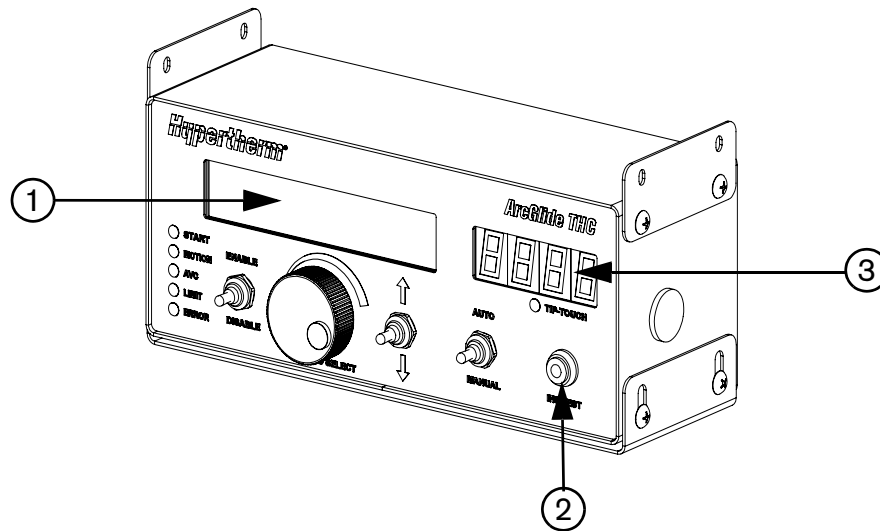

| Item | Kit number | Description | Quantity |
|------|------------|--|----------|
| 1 | 228589 | LCD display | 1 |
| 2 | 228583 | Momentary pushbutton switch | 1 |
| 3 | 228582 | HMI 7-segment display board | 1 |
| 4 | 228579 | 230 V surge board | 1 |
| 5 | 228590 | 120 VAC, 5 V, 5 amp, 25 W power source | 1 |
| 6 | 228581 | HMI processor board | 1 |

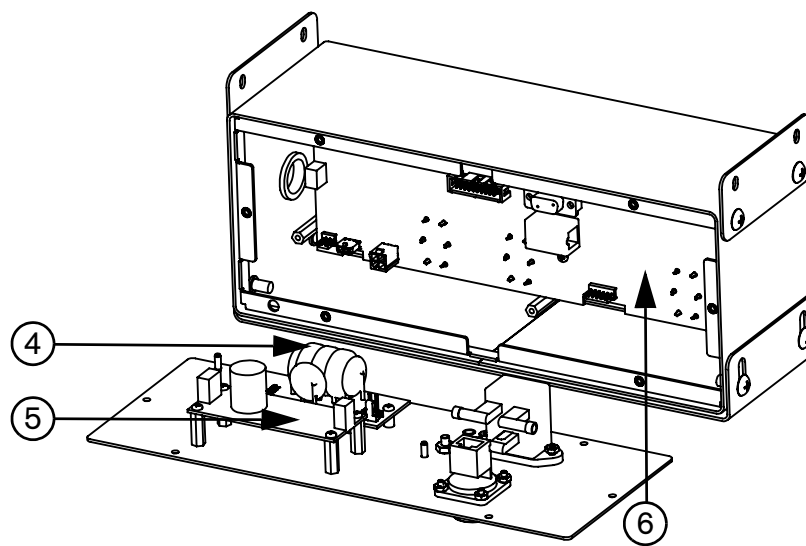

Plasma interface board

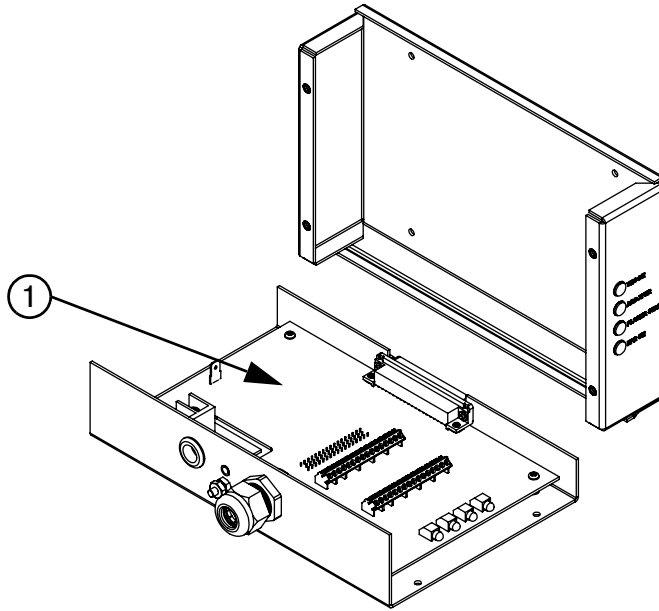

| Item | Kit number | Description | Quantity |
|------|------------|--|----------|
| 1 | 228576 | Discrete plasma interface board | 1 |
| | 141162 | Hypernet plasma interface board | 1 |
| | 228604 | Hypernet upgrade kit for HPR400XD and HPR800XD | 1 |
| | 228611 | Hypernet upgrade kit for HPR130XD and HPR260XD | 1 |



Section 2



Replacing ArcGlide parts

Use the instructions in the following sections to replace parts in the ArcGlide THC.

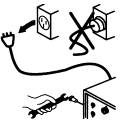

Replacement procedures are listed in order by the kit number for the part you are replacing. Before you begin a procedure, verify that you are using the procedure for the correct part.

| | | |
|---|--|--|
|  |  | <p>WARNING! ELECTRIC SHOCK CAN KILL</p> |
|  | | <p>Disconnect electrical power before performing any maintenance. See the <i>Safety</i> section in the <i>ArcGlide THC Instruction Manual</i> for more safety precautions.</p> |

| | | |
|---|--|--|
|  | | <p>CAUTION!</p> |
|  | | <p>Static electricity can damage circuit boards. Use proper precautions when handling printed circuit boards. Store PC boards in anti-static containers. Wear a grounded wrist strap when handling PC boards.</p> |

Accessing ArcGlide parts

The following procedures provide the initial steps for replacing parts in each of the ArcGlide modules:

Accessing lifter parts

1. Turn OFF power to the lifter and disconnect the power cable.
2. Remove the lifter from the gantry.
3. Remove the front of the lifter motor enclosure:
 - a. Remove the 4 screws on the front of the enclosure and set them aside.
 - b. Remove the 3 connectors for the switches and LED from the front cover on the lifter interface board.

Accessing control module parts

1. Turn OFF power to the control module and disconnect the power cable and other cables connected to the front panel.
2. Remove the control module from the cutting table.
3. Remove the 6 screws from the rear panel and set them aside.
4. Fold the rear panel down from the enclosure and lay it flat.

Accessing HMI parts

1. Turn OFF power to the HMI and disconnect the power and HMI cables.
2. Remove the 6 screws from the rear panel and set them aside.
3. Fold the rear panel down from the enclosure and lay it flat.

Replacement procedures

228576 – Plasma interface board

To remove the plasma interface board:

1. Turn OFF power to the plasma system.
2. Inside the plasma system, remove the 4 screws from the front of the plasma interface enclosure.
3. Label the wiring at terminal blocks J2 (inputs) and J3 (outputs) to insure that you can rewire them accurately.
4. Disconnect all wires from terminal blocks J2 and J3, the work and electrode wires from J4, and the ground wire connector.
5. Remove the 2 standoffs next to each of the two D-sub connectors on the front and bottom of the enclosure.
6. Remove the 4 screws from the standoffs at the corners of the plasma interface board.

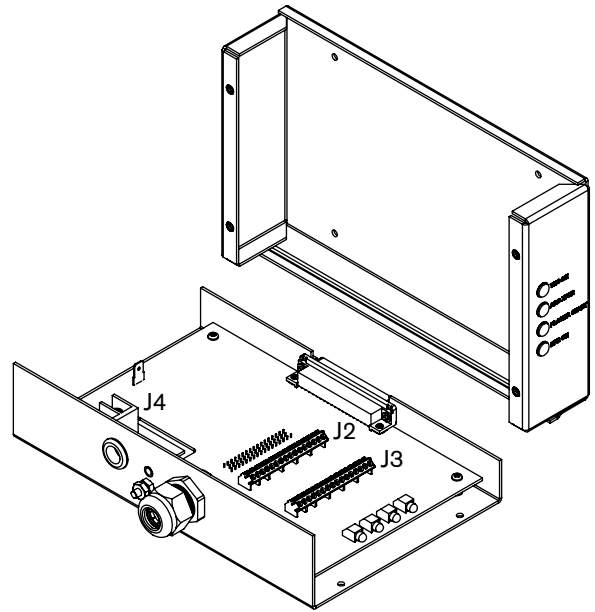

To replace the plasma interface board:

1. Place the new plasma interface board over the 4 standoffs and fasten the screws. Tighten the screws to 1.12 N·m (10 lb·in.).
2. Fasten the screws to the standoffs next to each of the two D-sub connectors. Tighten the screws to 0.67 N·m (6 lb·in.).
3. Fasten the ground wire to the grounding connector. Tighten the connector to 1.12 N·m (10 lb·in.).
4. Replace the work and electrode leads to the work and electrode terminal block (J4).
5. Using your labels, replace the input and output wires to the appropriate connectors on terminal blocks J2 and J3.
6. Replace the front of the enclosure and fasten the 4 screws. Tighten the screws to 1.12 N·m (10 lb·in.).
7. Restore power to the plasma system.

2 – Replacing ArcGlide parts

228577 – THC control interface board

Follow the steps in *Accessing control module parts* on page 12 to open the rear panel of the control module. Set aside all screws and other hardware for reuse.

To access the THC control interface board, you must use the following procedures to remove additional parts:

- 428081 – *Servo amplifier module* on page 36
- 228578 – *THC processor board* on page 15

To remove the THC control interface board:

1. On the outside of the front panel, remove the screws from around each black circular connector.
2. Remove the screw from the center bottom of the board.
3. Snap the board off the upper standoffs.
4. Lift the board off the standoffs and let the cables slip through the cutout in the board.

To replace the THC control interface board:

1. Thread the ribbon cables through the cutout.
2. Align the circular connectors through the front of the front panel.
3. Snap the board onto the standoffs.
4. Fasten the screw through the standoff in the center bottom of the board. Tighten the screw to 1.13 N·m (10 lb·in.).
5. Fasten the screws around the circular connectors on the front panel. Tighten the screws to 0.67 N·m (6 lb·in.).

Use the following procedures to replace additional parts:

- 228578 – *THC processor board* on page 15
- 428081 – *Servo amplifier module* on page 36

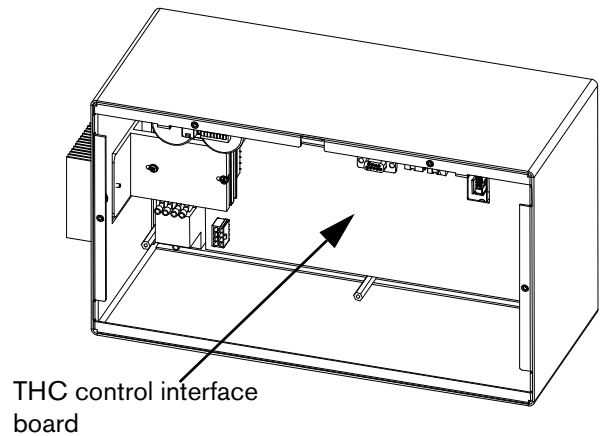

228578 – THC processor board

Follow the steps in *Accessing control module parts* on page 12 to open the rear panel. Set aside all screws and other hardware for reuse.

To access the THC processor board, you must use the following procedure to remove additional parts:

- 428081 – *Servo amplifier module* on page 36

To remove the THC processor board:

1. Remove the two screws that attach the THC processor board to the top of the enclosure.
2. Use a 1/4-inch socket wrench with an extension to remove the 6 standoffs from the inside of the front of the enclosure.
3. Remove the enclosure from the front panel assembly.
4. Disconnect the Ethernet cable from J8, the ribbon cables from J2 and J5, and the LCD cable from J4.
5. Remove the 2 screws that secure the board to the top of the enclosure.
6. Ease the board from the 100-pin connector on the THC control board.

To replace the THC processor board:

1. Carefully align J3 on the THC processor board with J1 on the THC control board. Gently press the connectors together to avoid bending the pins.
2. Fasten the two screws that secure the board to the top of the enclosure. Tighten the screws to 1.13 N·m (10 lb·in.).
3. Connect the Ethernet cable into J8, the ribbon cables into J2 and J5, and the LCD cable into J4.
4. Replace the enclosure on the front panel assembly, with the opening for the heatsink on the left, and the tabs that hold the control board on top.
5. Replace the 6 standoffs inside the front of the enclosure. Tighten the standoffs to 0.90 N·m (8 lb·in.).

Use the following procedures to replace additional parts:

- 428081 – *Servo amplifier module* on page 36

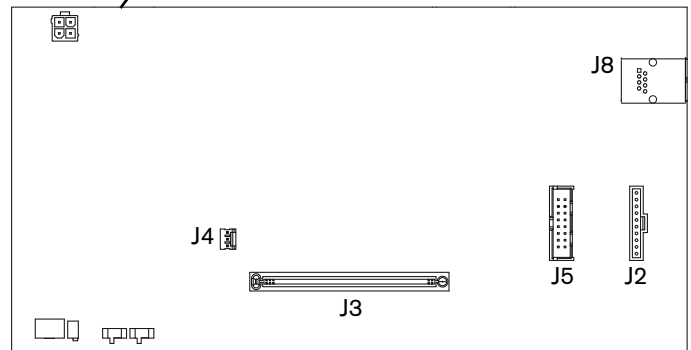
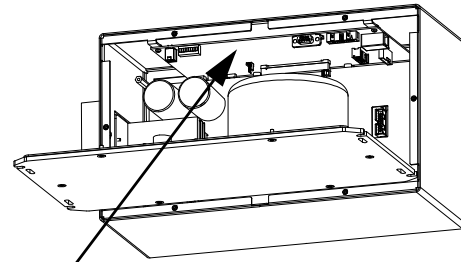

2 – Replacing ArcGlide parts

228579 – 230 V surge board

Follow the steps in *Accessing control module parts* or *Accessing HMI parts* on page 12 to open the rear panel. Set aside all screws and other hardware for reuse.

To remove the surge board:

1. Remove the cables from J1 and J2.
2. Remove the screws at either end of the board.
3. Remove the board from the standoffs.

To replace the surge board:

1. Place the new board over the standoffs and snap it into place.
2. Fasten the 2 screws at either end of the board. Tighten the screws to 1.13 N·m (10 lb·in.).
3. Replace the cable from the transformer (in the control module) or line filter (in the HMI) into J1.
4. Replace the cable from the power supply into J2.
5. Replace the rear panel of the enclosure and fasten the screws. Tighten the screws to 1.13 N·m (10 lb·in.).

Surge board

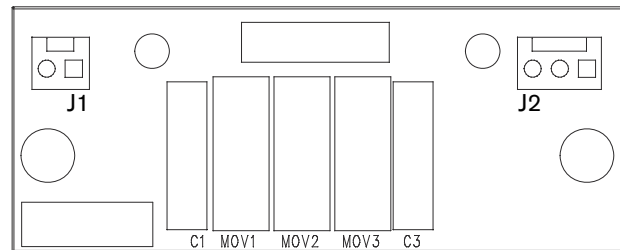
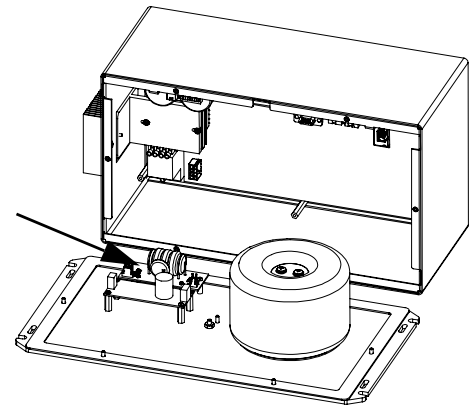

228580 – Lifter interface board

Follow the steps in *Accessing lifter parts* on page 12 to open the front cover of the motor enclosure. Set aside all screws and other hardware for reuse.

To remove the lifter interface board:

1. Remove the top of the motor enclosure by unfastening the 3 screws on the top of the enclosure and setting them aside.
2. Remove all cable connectors from the lifter interface board, except for the connector for the ohmic contact wire in J5.
3. Remove the bottom panel of the board assembly. This panel has Danger High-Voltage printed on the bottom side. Use needle-nose pliers to depress the tabs on the standoffs.
4. Remove the ohmic wire connector from J5.
5. Remove the 4 screws around the circular, lifter cable connector.
6. Remove the 2 screws from the standoffs.
7. Pull the board from the standoffs.

To replace the lifter interface board:

1. Fit the new board over the standoffs and fasten the 2 screws into the standoffs. Tighten the screws to 1.13 N-m (10 lb-in.).
2. Fasten the 4 screws around the circular connector. Tighten the screws to 0.67 N-m (6 lb-in.).
3. Install the ohmic wire in terminal block J5 on the underside of the lifter interface board.
4. Snap the bottom panel of the board assembly onto the plastic standoffs.
5. Replace the top cover of the motor enclosure and fasten the 3 screws. Tighten the screws to 1.13 N-m (10 lb-in.).

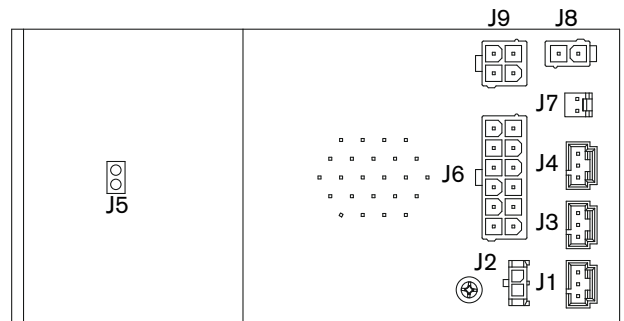
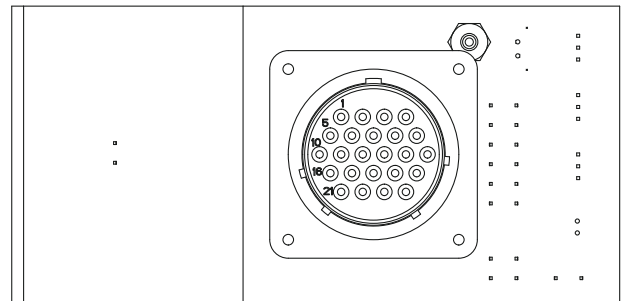
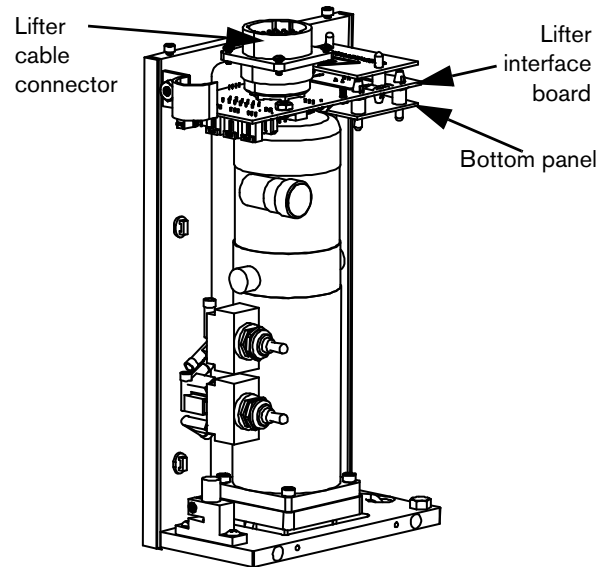

2 – Replacing ArcGlide parts

6. Install cable connectors in the following connectors on the lifter interface board:

- J1 Upper limit switch
- J3 Lower limit switch
- J4 Breakaway
- J6 Motor brake encoder
- J7 Laser pointer

7. Install the connectors from the switches and LED on the front cover to the lifter interface board:

- J2 LED
- J8 Enable/disable switch
- J9 Up/down switch

8. Replace the front cover of the motor enclosure and fasten the 4 screws. Tighten the screws to 1.13 N·m (10 lb·in.).

228581 – HMI processor board

Follow the steps in *Accessing HMI parts* on page 12 to open the rear panel. Set aside all screws and other hardware for reuse.

To remove the HMI processor board:

1. Remove the Ethernet cable connector from J7 and the red and black wires to the power source from J12.
2. Remove the 3 toggle switch boots on the front of the enclosure.
3. Remove 6 standoffs around the processor board.
4. Push gently on the board to remove it and the front panel from the enclosure.
5. Remove cables from connectors J3, J4, J8, J9, J10, J11.
6. Remove the screws from the standoffs at the upper corners and the lower center of the board.
7. Remove the board from the front panel.
8. On the front of the board, remove the hex nuts and round washers from the toggle switches. Save the washers for reuse.

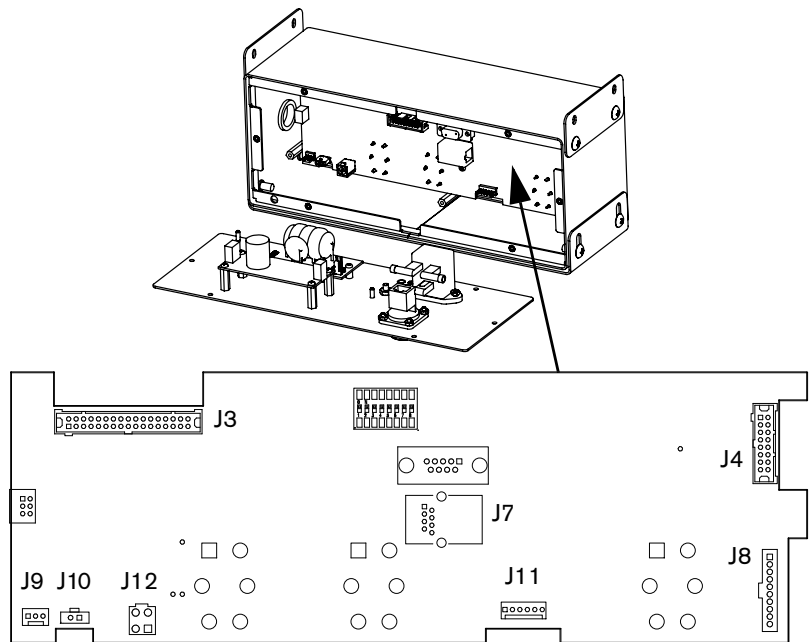

To replace the HMI processor board:

1. Remove the 9/16-inch hex nuts from the toggle switches on the front of the new board, install the washers, and finger-tighten the hex nuts plus a 1/4 turn.
2. Place the new board over the standoffs on the front panel.
3. Fasten the screws in the standoffs. Tighten the screws to 1.13 N·m (10 lb·in.).
4. Replace the cable connectors in J3, J4, J8, J9, J10, J11.
5. Replace the new board and front panel in the enclosure with the station switch aligned with the rubber gasket and hole in the side of the enclosure.
6. Replace the 6 standoffs around the processor board. Tighten the standoff to 0.90 N·m (8 lb·in.).
7. Reconnect the Ethernet cable to J7 and red and black wires to J12.
8. Fit the back cover on the enclosure and fasten the 6 screws. Tighten the screws to 1.13 N·m (10 lb·in.).
9. Replace the hex boots around the toggle switches on the front panel of the enclosure and finger-tighten them.

228582 – HMI 7-segment display board

Follow the steps in *Accessing HMI parts* on page 12 to open the rear panel of the HMI enclosure. Set aside all screws and other hardware for reuse.

To access the HMI 7-segment display board, you must use the following procedure to remove additional parts:

- 228581 – HMI processor board on page 18

To remove the display board:

1. Remove the wide ribbon cable from the display board.
2. Remove the threaded standoff and washer and save them for reuse.
3. Remove the 3 screws from the remaining standoffs.
4. Lift the LED board from the standoffs.

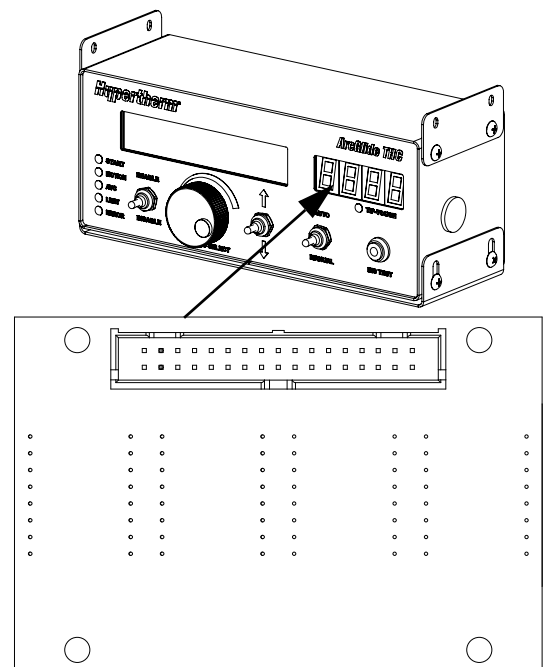

2 – Replacing ArcGlide parts

To replace the display board:

1. Fit the new LED board over the standoffs with the 34-pin connector at the top.
2. Replace the threaded standoff and washer in the upper left corner of the board. Tighten the standoff to 0.90 N·m (8 lb·in.).
3. Replace the 3 screws in the remaining standoffs. Tighten the screws to 1.13 N·m (10 lb·in.).
4. Insert the connector for the ribbon cable in the 34-pin connector on the board.

Use the following procedure to replace additional parts:

- 228581 – HMI processor board on page 18

228583 – Momentary pushbutton switch

Follow the steps in *Accessing HMI parts* on page 12 to open the rear panel of the HMI enclosure. Set aside all screws and other hardware for reuse.

To access the momentary pushbutton switch, you must use the following procedure to remove additional parts:

- 228581 – HMI processor board on page 18

To remove the momentary pushbutton switch:

1. Remove the 14-mm hex nut from the back of the switch on the inside of the front panel.
2. Remove the switch from the front of the front panel.

To replace the momentary pushbutton switch:

1. Thread the cable for the replacement switch through the switch opening in the front panel.
2. Replace the hex nut around the base of the switch and tighten it to 1.35 N·m (12 lb·in.).

Use the following procedures to remove and replace additional parts:

- 228581 – HMI processor board on page 18

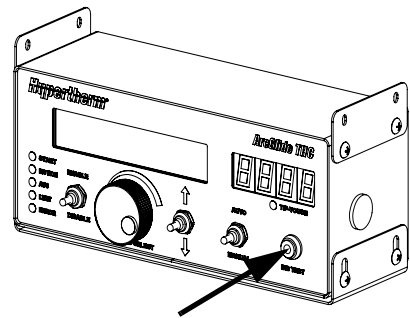

228584 – Torch up/down switch

Follow the steps in *Accessing lifter parts* on page 12 to open the front cover of the motor enclosure. Set aside all screws and other hardware for reuse.

To remove the torch up/down switch:

1. Remove the hex boot around the up/down switch on the front cover of the motor enclosure and set it aside.
2. Pull the switch through the back of the front cover.
3. Remove the hex nut and washer from the back of the switch. Set the washer aside.

To replace the torch up/down switch:

1. Remove the hex nut from the back of the new switch.
2. Install the washer on the back of the switch.
3. Replace the hex nut and finger-tighten it plus 1/4 turn.
4. Align the key in the switch opening with the slot on the switch and push the switch into place.
5. Finger tighten the hex boot around the switch on the front cover.
6. Replace the front cover of the motor enclosure and fasten the 4 screws. Tighten the screws to 1.13 N·m (10 lb·in.).

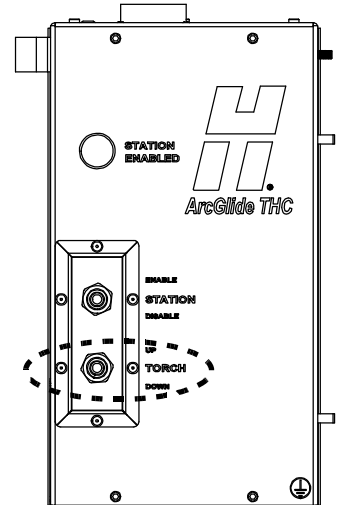

2 – Replacing ArcGlide parts

228585 – Enable/disable switch

Follow the steps in *Accessing lifter parts* on page 12 to open the front cover of the motor enclosure. Set aside all screws and other hardware for reuse.

To remove the enable/disable switch:

1. Remove the hex boot around the enable/disable switch on the front cover of the motor enclosure and set it aside.
2. Pull the switch through the back of the front cover.
3. Remove the hex nut and washer from the back of the switch. Set the washer aside.

To replace the torch enable/disable switch:

1. Remove the hex nut from the back of the new switch.
2. Install the washer on the back of the switch.
3. Replace the hex nut and finger-tighten it plus a 1/4 turn.
4. Align the key in the switch opening with the slot on the switch and push the switch into place.
5. Finger-tighten the hex boot around the switch on the front cover.
6. Replace the front cover of the motor enclosure and fasten the 4 screws. Tighten the screws to 1.13 N·m (10 lb·in.).

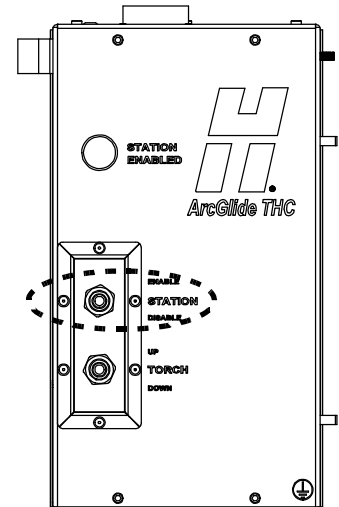

228586 – Lifter lower limit proximity switch

Follow the steps in *Accessing lifter parts* on page 12 to open the front cover of the motor enclosure. Set aside all screws and other hardware for reuse.

To remove the lifter lower limit proximity switch:

1. Before you turn OFF power to the ArcGlide lifter, move the lifter carriage assembly to the vertical center of the slide.
2. Turn OFF power to the lifter.
3. Remove the 4 screws from the front panel of the slide enclosure.
4. Slide the front panel down and off the slide.
5. Remove the 4 screws from the right side panel of the slide enclosure and set the shield and panel aside.
6. Remove the 3 screws from the bottom bracket of the slide enclosure and set the panel aside.
7. Loosen the screw on the top of the lower limit switch and slide the switch down and out of the track along the side of the lifter slide.
8. Remove the screw and nut from the top and bottom of the switch.
9. Slide the cover of the track down and out of the track.
10. Disconnect the cable with the green heatshrink from J3 on the lifter interface board.
11. Cut the cable ties that secure the switch cables to the motor enclosure.
12. Loosen the screw from the upper limit proximity switch (with the yellow heatshrink) and slide the switch out of the top of the track.
13. Remove the lower limit switch cable from the length of the track and the motor enclosure.

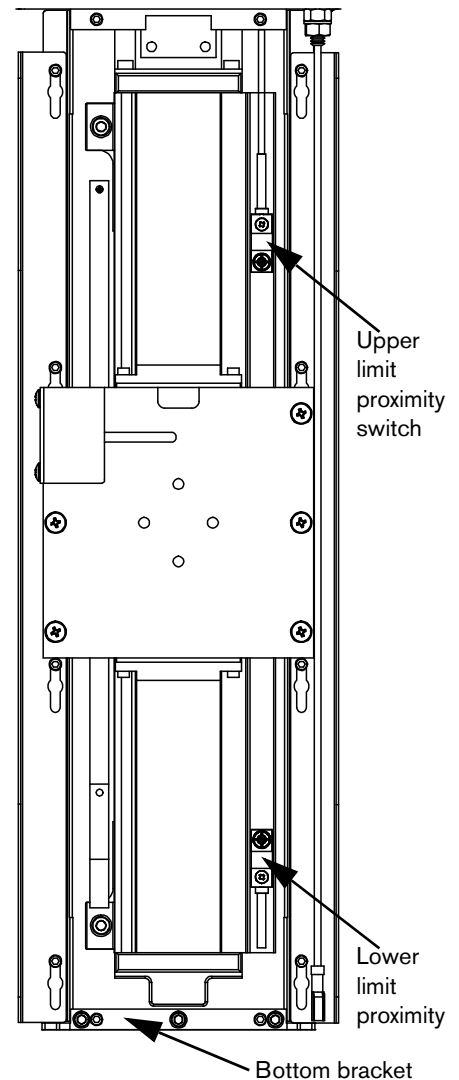

To replace the lifter lower limit proximity switch:

1. Thread the end of the new lower limit switch cable with the connector and green heatshrink through the hole in the bottom right of the motor enclosure.
2. Feed the remainder of the cable into the track along the side of the lifter slide.
3. Replace the cover on the track.
4. Insert the screw through the top of the new switch.
5. Attach the nut to the screw on the bottom of the switch so that the nut is flush with the end of the screw.
6. Insert the switch into the track with the imprint of a target toward the top of the lifter.

2 – Replacing ArcGlide parts

7. Adjust the switch vertically until the center of the target is 60.3 mm, +/- 0.5 mm (2.375 inches, +/- 0.020 inch) from the bottom of the track.
8. Tighten the screw in the top of the lower limit switch to 0.67 N·m (6 lb·in.).
9. Pull the cable up through the track so that the bottom of the loop in the cable is even with the bottom of the track.
10. Slide the cover of the track down until it stops against the lower limit switch.
11. Slide the upper limit proximity switch onto the top of the track and down until it stops against the track cover.
12. Tighten the screw in the top of the upper limit switch to 0.67 N·m (6 lb·in.).
13. In the motor enclosure, route the lower limit switch cable along the side and to the back of the motor.
14. Insert the connector of the switch cable into J3 on the lifter interface board.
15. Use new cable ties to secure the limit switch cables to the 3 cable tie anchors in the motor enclosure.
16. Replace the bottom bracket of the slide enclosure and fasten the 3 screws. Tighten the screws to 2.25 N·m (20 lb·in.).
17. Replace the right side panel and shield of the slide enclosure and fasten the 4 screws. Tighten the screws to 1.13 N·m (10 lb·in.).
18. Replace the front panel of the slide enclosure and fasten the 4 screws. Tighten the screws to 1.13 N·m (10 lb·in.).
19. Install the connectors from the switches and LED on the front cover to the lifter interface board:

| | |
|----|-----------------------|
| J7 | Laser pointer |
| J8 | Enable/disable switch |
| J9 | Up/down switch |
20. Replace the front cover of the motor enclosure and fasten the 4 screws. Tighten the screws to 1.13 N·m (10 lb·in.).

228587 – Lifter upper limit proximity switch

Follow the steps in *Accessing lifter parts* on page 12 to open the front cover of the motor enclosure. Set aside all screws and other hardware for reuse.

To remove the lifter upper limit proximity switch:

1. Before you turn OFF power to the ArcGlide lifter, move the lifter carriage assembly to the vertical center of the slide.
2. Turn OFF power to the lifter.
3. Remove the 4 screws from the front panel of the slide enclosure and set the panel aside.
4. Remove the 4 screws from the right side panel of the slide enclosure and set the shield and panel aside.
5. Loosen the screw from the upper limit switch and slide the switch from the top of the track along the side of the lifter slide.
6. Remove the screw and nut from the top and bottom of the switch.
7. Disconnect the cable with the yellow heatshrink from J1 on the lifter interface board.
8. Cut the 3 cable ties that secure the switch cables to the motor enclosure.
9. Pull the cable through the bottom of the motor enclosure.

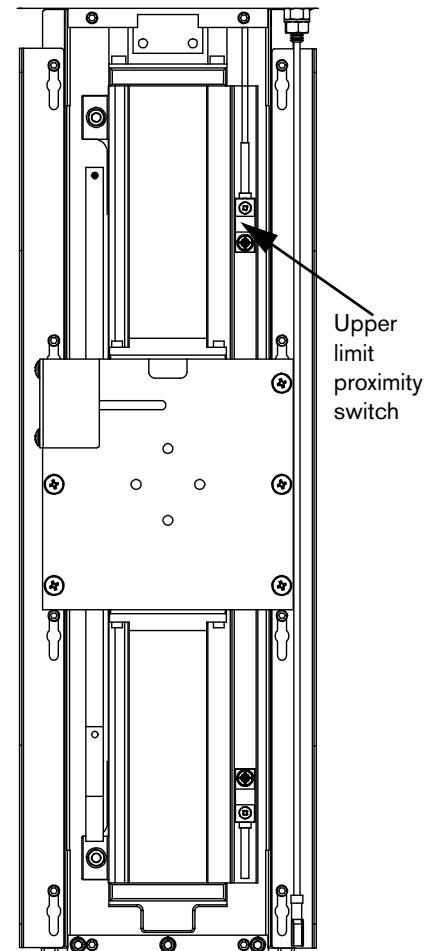

To replace the lifter upper limit proximity switch:

1. Fasten the screw through the top of the new switch.
2. Attach the nut to the end of the screw on the bottom of the switch but tighten it only until the outside edge of the nut is flush with the end of the screw.
3. Slide the switch over the top of the track.
4. Slide the switch down the track until it stops against the track cover.
5. Tighten the screw in the top of the switch to 0.67 N-m (6 lb-in.).
6. Insert the end of the new switch cable with the connector and yellow heatshrink through the hole in the bottom of the motor enclosure.
7. In the motor enclosure, route the switch cable along the side and to the back of the motor.
8. Insert the connector of the switch cable into J1 on the lifter interface board.
9. Use new cable ties to secure the limit switch cables to the 3 cable tie anchors in the motor enclosure.

2 – Replacing ArcGlide parts

10. Install the connectors from the switches and LED on the front cover to the lifter interface board:

- J7 Laser pointer
- J8 Enable/disable switch
- J9 Up/down switch

11. Replace the right side panel and shield of the slide enclosure and fasten the 4 screws. Tighten the screws to 1.12 N·m (10 lb·in.).

12. Replace the front panel of the slide enclosure and fasten the 4 screws. Tighten the screws to 1.13 N·m (10 lb·in.).

13. Replace the front cover of the motor enclosure and fasten the 4 screws. Tighten the screws to 1.13 N·m (10 lb·in.).

228588 – Station Enable 5 V LED

Follow the steps in *Accessing lifter parts* on page 12 to open the front cover of the motor enclosure. Set aside all screws and other hardware for reuse.

To remove the Station Enable 5 V LED:

1. Remove the nut and washer around the LED inside the front cover.
2. Pull the LED and cable through the front cover.

To replace the Station Enable 5 V LED:

1. Thread the cable and the new LED through the hole in the front cover.
2. Fasten the nut and washer around the LED on the front panel. Finger-tighten the nut plus a 1/4 turn.
3. Replace the front cover of the motor enclosure and fasten the 4 screws. Tighten the screws to 1.13 N·m (10 lb·in.).

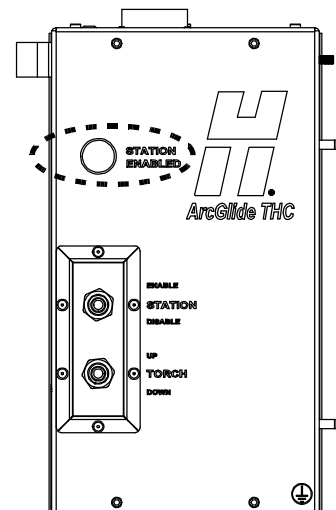

228589 – LCD display

The LCD display is used in both the control module and the HMI.

To remove the LCD display in the control module, follow the steps in *Accessing control module parts* on page 12 to open the rear panel of the control module. Set aside all screws and other hardware for reuse.

To access the LCD display, you must use the following procedures to remove additional parts:

- 428081 – Servo amplifier module on page 36
- 228578 – THC processor board on page 15
- 228577 – THC control interface board on page 14

Follow the instructions on page 28 to replace the LCD display in an HMI.

To remove the LCD display in a control module:

1. Remove the ribbon cable from the LCD display board.
2. Cut the cable tie that attaches the red and black wires to the LCD display.
3. Remove the 4 screws from the standoffs at the corners of the display board.
4. Lift the board off the standoffs.

To replace the LCD display in a control module:

1. Fit the new LCD display board over the standoffs with the black connector next to the green ribbon cable.
2. Fasten the 4 screws in the standoffs. Tighten the screws to 1.13 N·m (10 lb·in.).
3. Use cable ties to secure the red and black wires to the cable tie anchor on the front of the enclosure.
4. Connect the 16-pin ribbon cable to the black connector on the board.

Use the following procedures to replace additional parts:

- 228577 – THC control interface board on page 14
- 228578 – THC processor board on page 15
- 428081 – Servo amplifier module on page 36

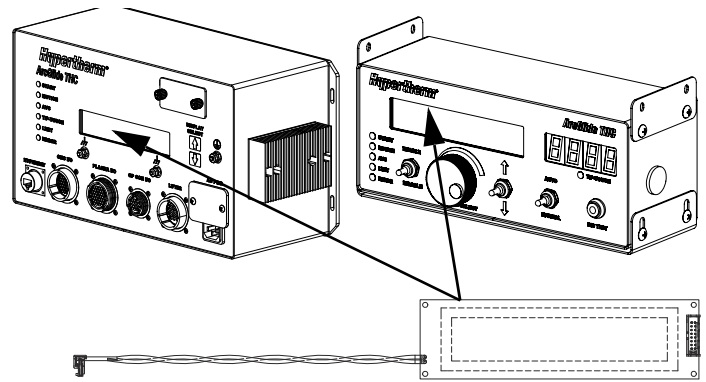

2 – Replacing ArcGlide parts

To remove the LCD display in the HMI, follow the steps in *Accessing HMI parts* on page 12 to open the rear panel of the HMI. Set aside all screws and other hardware for reuse.

To access the LCD display, you must use the following procedure to remove additional parts:

- 228581 – HMI processor board on page 18

To remove the LCD display in an HMI:

1. Remove the ribbon cable connector from the LCD display board.
2. Remove the threaded standoff from the upper right of the board.
3. Remove the remaining 3 screws from the corners of the display board.
4. Lift the board off the standoffs.

To replace the LCD display in an HMI:

1. Fit the new LCD display board over the standoffs with the black connector next to the green ribbon cable.
2. Replace the threaded standoff screw in the upper right. Tighten the standoff to 0.90 N·m (8 lb·in.).
3. Fasten the 3 screws in the remaining standoffs. Tighten the screws to 1.13 N·m (10 lb·in.).
4. Fasten the red and black wires to the cable tie anchor on the front of the enclosure.
5. Connect the ribbon cable to the black connector on the display board.

Use the following procedure to replace additional parts:

- 228581 – HMI processor board on page 18

228590 – 120 VAC, 5 V, 5 amp, 25 W power source

Follow the steps in *Accessing control module parts* or *Accessing HMI parts* on page 12 to open the rear panel of the enclosure. Set aside all screws and other hardware for reuse.

To remove the power source:

1. Remove the cable connectors for the red and black wires to the processor board and the black and white wires to the surge board.
2. Remove the screws from the standoffs.
3. Lift the board off the standoffs.

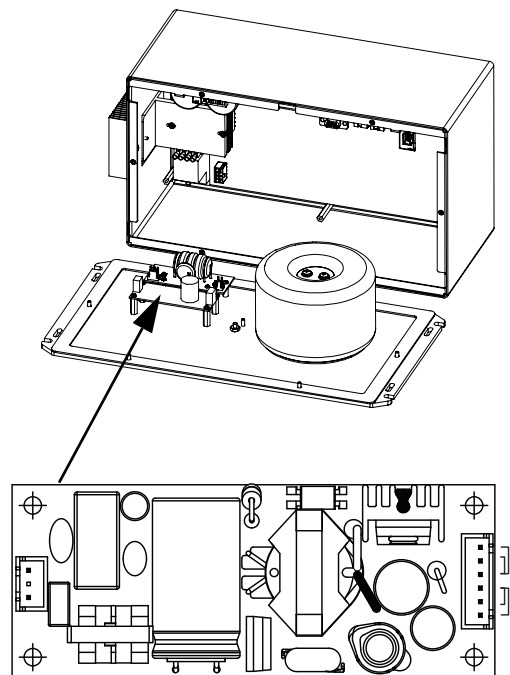

To replace the power source:

1. Place the new board over the standoffs with the larger connector on the side of the transformer (in the control module) or the line filter (in the HMI).
2. Fasten the screws into the standoffs. Tighten the screws to 0.67 N·m (6 lb·in.).
3. Replace the connectors for the red and black wires and the black and white wires.
4. Replace the rear panel and fasten the screws. Tighten the screws to 1.13 N·m (10 lb·in.).

228591 – Lifter slide

The procedure to replace the lifter slide must be performed by trained technicians.

Improper assembly can result in binding and alignment problems with the proximity switches and the laser pointer.

228592 – Laser pointer diode

Follow the steps in *Accessing lifter parts* on page 12 to open the front cover of the motor enclosure. Set aside all screws and other hardware for reuse.

To remove the laser pointer diode:

1. Cut the cable ties that secure the laser diode wires.
2. Remove the cable connector from J7 on the lifter interface board.
3. Loosen, but do not remove, the screw on the outside of the bracket for the laser pointer.
4. Pull the pointer from the bracket.

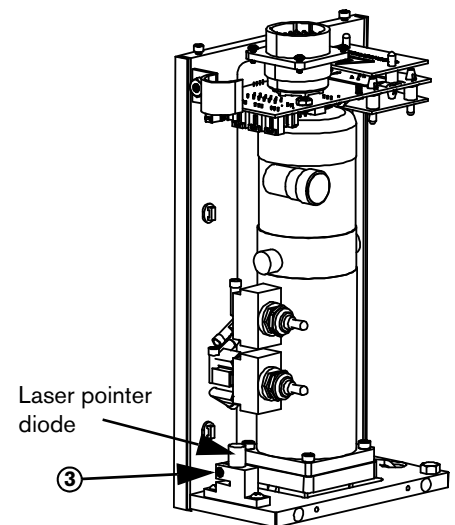

To replace the laser pointer diode:

1. Push the new pointer to the bottom of the bracket. The bracket automatically aligns the laser.
2. Tighten the screw in the pointer bracket to 0.22 N·m (2 lb·in.).
3. Reconnect the diode cable connector to J7 on the lifter interface board.
4. Secure the diode cable connector with cable ties to the cable anchor on the enclosure.
5. Replace the front cover of the motor enclosure and fasten the 4 screws. Tighten the screws to 1.13 N·m (10 lb·in.).

2 – Replacing ArcGlide parts

228593 – 11.34 kg (25 lb) Magnetic breakaway

228607 – 4.54 kg (10 lb) Magnetic breakaway

The procedures for replacing both magnetic breakaways are the same.

To remove the magnetic breakaway:

1. Use the torch as a lever to separate the breakaway from the breakaway mounting plate.
2. Thread the end of the breakaway tether through the breakaway tether bracket and set it aside.
3. Loosen the two front screws on the front of the torch bracket and remove the front of the torch bracket and remove the torch.
4. Remove the 4 screws that fasten the back of the torch bracket to the breakaway.
5. Remove the screw in the breakaway sensor switch at the top of the breakaway mounting plate.
6. Remove the 4 screws that fasten the breakaway mounting plate to the torch mounting plate.
7. Lift the breakaway mounting plate off the torch mounting plate and thread the breakaway sensor switch through the opening.

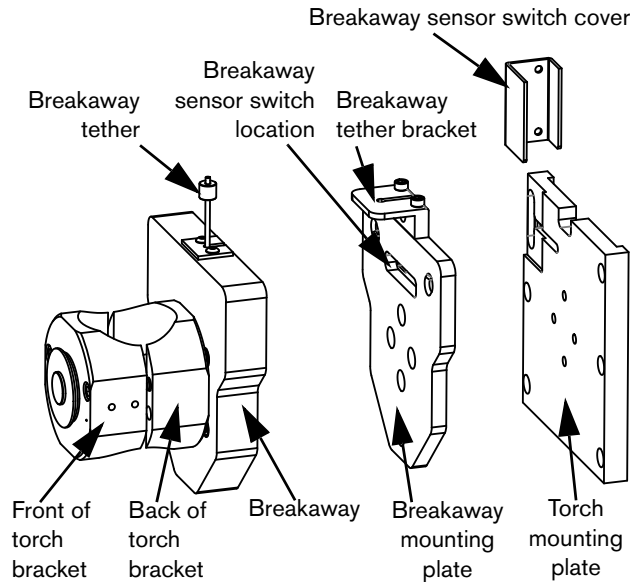

To replace the magnetic breakaway:

1. Thread the breakaway sensor switch through the opening in the top of the breakaway mounting plate and fit the mounting plate to the top of the torch mounting plate.
2. Apply 1 drop of thread sealant on the screw threads and fasten the 4 screws that hold the breakaway mounting plate to the torch mounting plate. Tighten the screws to 5.08 N·m (45 lb·in.).
3. Fasten the screw that attaches the breakaway sensor switch at the top of the breakaway mounting plate. Tighten the screw to 0.67 N·m (6 lb·in.).
4. Apply 1 drop of thread sealant on the screw threads and fasten the 4 screws through the back of the torch bracket, into the breakaway. Tighten the screws to 5.08 N·m (45 lb·in.).
5. Position the torch in the back of the torch bracket.
6. Place the front of the torch bracket over the torch and fasten it to the back of the torch bracket with the 2 screws. Tighten the screws to 1.13 N·m (10 lb·in.).
7. Thread the end of the breakaway tether through the breakaway tether bracket and return the torch and breakaway to the breakaway mounting plate.
8. Use a level to verify that the torch is at a 90° angle to the workpiece.

228595 – Lifter motor brushes

Follow the steps in *Accessing lifter parts* on page 12 to open the front cover of the motor enclosure. Set aside all screws and other hardware for reuse.

To remove the lifter motor brushes:

1. Disconnect the connectors on the brush housing covers on either side of the motor.
2. Use a blade screwdriver to remove the cover on each housing.
3. Pull the motor brushes from the housings.

To replace the lifter motor brush:

1. Insert new brushes into the brush housings so that the connector fits into the cutout on the front of the housing.
2. Push the connector tab in as far as possible and screw on the cover. Tighten the cover to 0.67 N·m (6 lb·in.).



Verify that you screw the red cover onto the housing on the left side of the motor and the black cover on the housing on the right side of the motor.

3. Reconnect the red and black wire connectors to the connector in the brush housing with the corresponding colored cover.

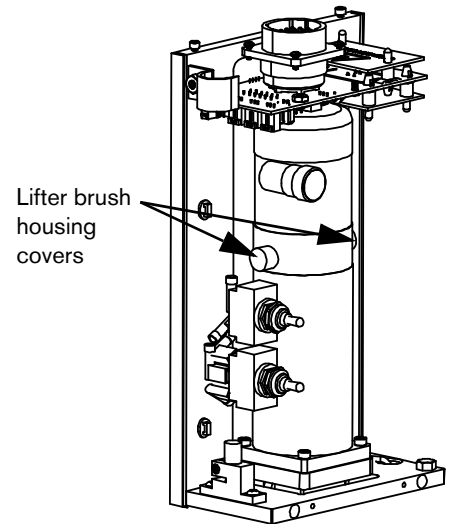

228597 – Pneumatic breakaway

To remove the pneumatic breakaway:

1. Remove the air hose and yellow electrical cables.
2. Remove the front of the torch bracket.
3. Remove the screws on the clamp that holds the mounting ring on the back half of the torch bracket.
4. Remove the clamp ring from the back of the torch bracket.
5. Remove the 6 screws from the holes around the edge of the breakaway.
6. Lift the breakaway off the fiberglass base.
7. Remove the 4 screws from the fiberglass base.

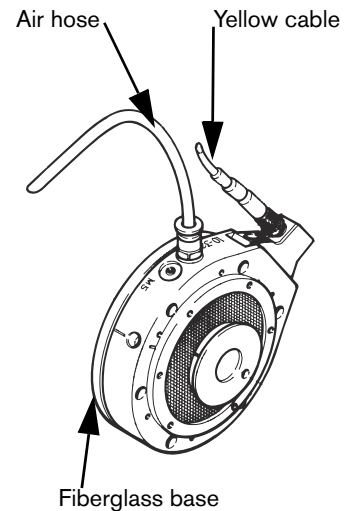

2 – Replacing ArcGlide parts

To replace the pneumatic breakaway:

1. Position the new fiberglass base and fasten the 4 screws.
2. Place the new breakaway over the fiberglass base and fasten the 6 screws in the holes around the edge of the breakaway.
3. Replace the clamp ring around the back of the torch bracket.
4. Fasten the screws on the clamp.
5. Replace the front of the torch bracket.
6. Replace the air hose and yellow electrical cables.
7. Use a level to verify that the torch is at a 90° angle to the workpiece.

228608 – Breakaway cable

Follow the steps in *Accessing lifter parts* on page 12 to open the front cover of the motor enclosure. Set aside all screws and other hardware for reuse.

To remove the breakaway sensor switch:

1. Remove the 4 screws from the front panel of the slide enclosure and set the panel aside.
2. Remove the 4 screws from the left side panel and set the panel and shield aside.
3. Use the torch as a lever and remove the torch and the breakaway from the lifter.
4. Release the breakaway tether by threading it through the tether bracket.
5. Unfasten the screw in the breakaway sensor switch in the slot at the top of the breakaway mounting plate. Set the screw aside.
6. To remove the breakaway mounting plate, remove the 4 screws and gently push the breakaway sensor switch through the slot in the back of the breakaway mounting plate.
7. Remove the breakaway sensor switch cover by unfastening the two screws. Set the cover and screws aside.
8. Remove the 6 screws from the sides of the torch mounting plate and set them aside and lift the torch mounting plate off the lifter mounting plate.
9. Gently pull the breakaway sensor switch through the slot in the back of the torch and lifter mounting plates.

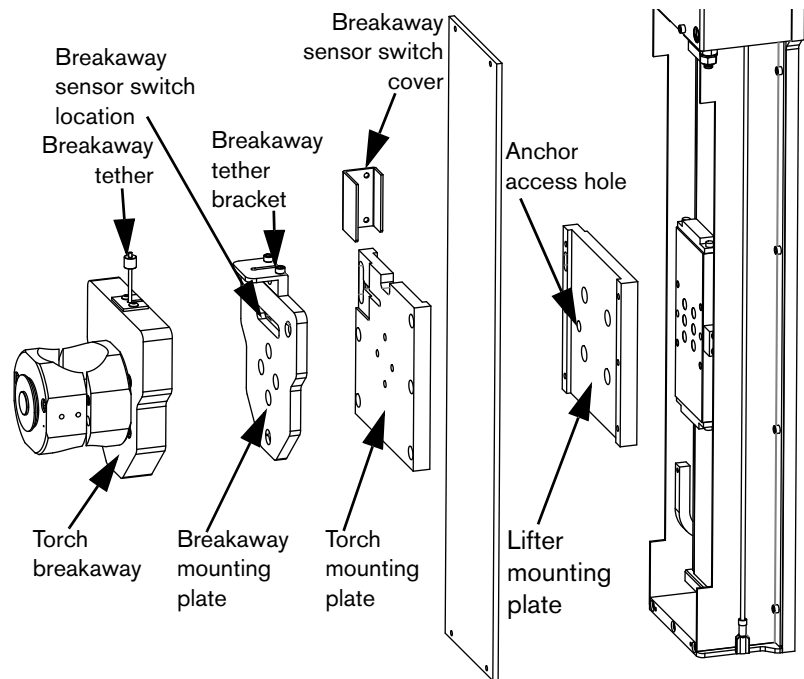

To remove the breakaway flex track:

1. Insert a screwdriver through the access hole in the lifter mounting plate and remove the screw from the flex track anchor. You may need to move the breakaway cable down to access this screw.
2. Lift the breakaway cable from the flex track anchor at the top of the slide and remove the screw in the anchor.
3. Cut the cable ties that secure the breakaway cable in the motor enclosure and disconnect the connector from J4 on the lifter interface board.
4. Remove the cable from the slide and motor enclosures.

To remove the breakaway cable from the flex track:

1. Remove the final segment on the end with the cable connector that you removed from the lifter interface board and set it aside for reuse.
2. Slip the individual wires between the cable jacket and the PCB connector through the slot in each segment of the track as you pull down on the cable until the cable is free of the track.

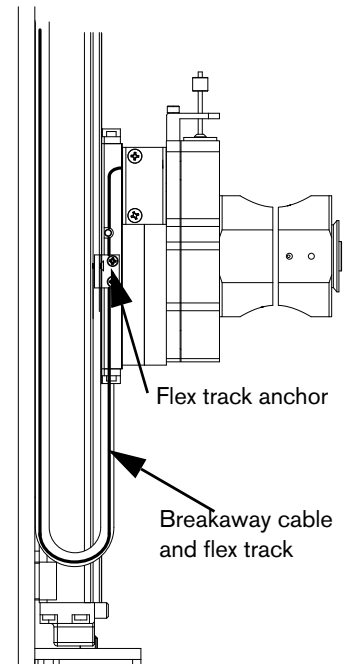

To replace the breakaway cable in the flex track:

1. Slip the individual wires between the cable jacket and the PCB connector through the slot in each segment of the track as you pull it to the top of the track.
2. Replace the final segment of the track under the PCB connector.

 Verify that the alignment pin on this final segment is on the same side of the flex track as the slots in the segments of the track.

To replace the breakaway flex track:

1. Insert the alignment pin in the flex track anchor next to the top of the slide and replace the screw that secures the anchor. Tighten the screw to 0.33 N·m (3 lb-in.).
2. Thread the cable connector through the hole in the bottom of the motor enclosure and install the connector in J4 in the lifter interface board.
3. On the end of the flex track with the breakaway sensor switch, insert the alignment pin in the anchor on the back of the lifter mounting plate. Fasten the screw through the access hole in the lifter mounting plate and into the flex track anchor. Tighten the screw to 0.33 N·m (3 lb-in.).
4. Verify that the switch cable fits through both end segments of the flex track and around the lifter mounting block below the motor enclosure.

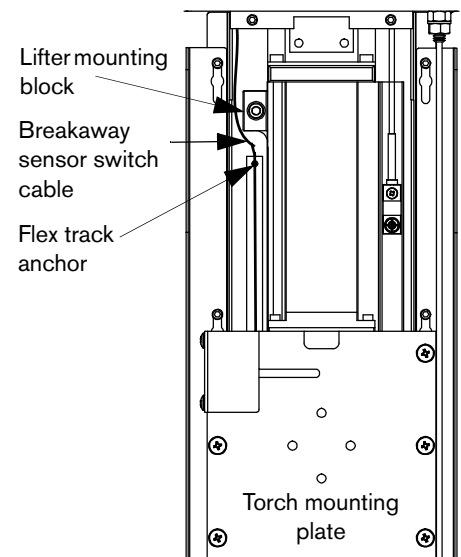

2 – Replacing ArcGlide parts

To replace the breakaway sensor switch:

1. Replace the torch mounting plate on the lifter mounting plate. Apply 1 drop of thread sealant on the screw threads and fasten the 6 screws. Tighten the screws to 1.69 N·m (15 lb·in.).
2. Thread the breakaway sensor switch through the holes in the torch and lifter mounting plates.
3. Thread the breakaway sensor cable through the track on the torch mounting plate then through the breakaway mounting plate.
4. Apply 1 drop of thread sealant on the screw threads and fasten the 4 screws through the breakaway mounting plate to the torch mounting plate. Tighten the screws to 5.08 N·m (45 lb·in.).
5. Pull the switch cable to remove the slack and fasten the screw that secures the switch in the breakaway mounting plate. Tighten the screw to 0.67 N·m (6 lb·in.).
6. Fit the switch cable through the track on the back of the lifter mounting plate.
7. Slide the breakaway sensor switch cable cover over the switch cable and the sides of the torch mounting plate and lifter mounting plate. Secure the cover with 2 screws. Tighten the screws to 1.13 N·m (10 lb·in.).
8. Adjust the cable to remove slack from the back of the lifter mounting plate, through the flex track, and into the motor enclosure.
9. Replace the breakaway tether by threading it through the tether bracket.
10. Holding the torch, replace the magnetic breakaway on the breakaway mounting plate.
11. Use a level to verify that the torch is at a 90° angle to the workpiece.
12. Replace the left side panel and shield of the slide enclosure and fasten the 4 screws. Tighten the screws to 1.13 N·m (10 lb·in.).
13. Replace the front panel of the slide enclosure and fasten the 4 screws. Tighten the screws to 1.13 N·m (10 lb·in.).

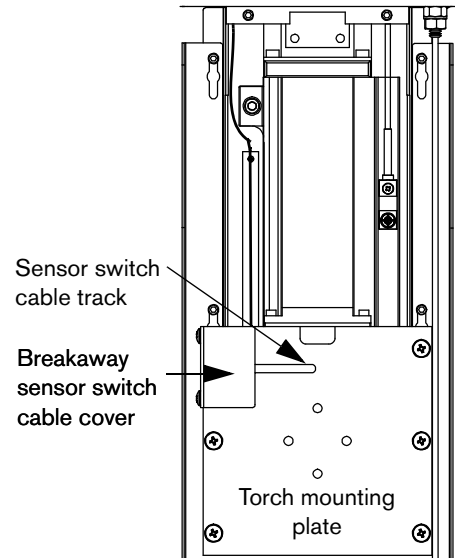

228938 – 20 kf (45 lbf) Replacement magnets

228939 – 35.7 kf (78.7 lbf) Replacement magnets

The procedures for replacing both types of breakaway magnets are the same.

To remove the breakaway magnets:

1. Use the torch as a lever to separate the breakaway from the breakaway mounting plate.
2. Thread the end of the breakaway tether through the breakaway tether bracket and set the breakaway aside.
3. Loosen the two front screws on the front of the torch bracket and remove the top of the torch bracket and remove the torch.
4. Remove the 4 screws that fasten the back of the torch bracket to the breakaway.
5. Remove the socket head screws that hold the magnets within the back of the breakaway.

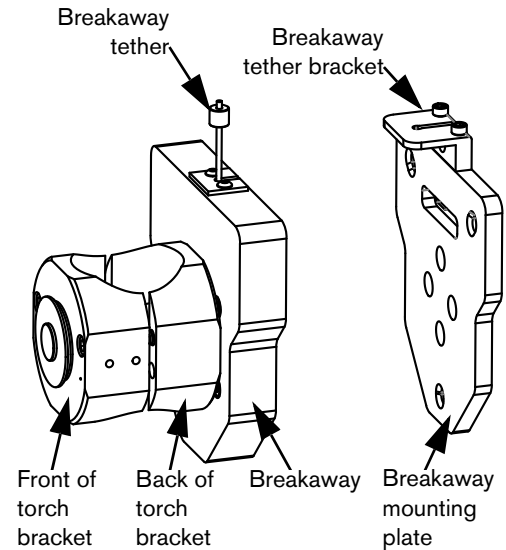

To replace the breakaway magnets:

1. Apply 1 drop of thread sealant on the screw threads and install new magnets into the back of the breakaway with the new socket head cap screws.
2. Apply 1 drop of thread sealant on the screw threads and fasten 4 screws through the back half of the torch bracket into the breakaway. Tighten the screws to 5.08 N·m (45 lb·in.).
3. Replace the torch in the back of the torch bracket.
4. Fasten the 2 screws through the front of the torch bracket into the back of the torch bracket. Tighten the screws to 1.13 N·m (10 lb·in.).
5. Thread the end of the breakaway tether through the breakaway tether bracket.
6. Replace the breakaway on the breakaway mounting plate.
7. Use a level to verify that the torch is at a 90° angle to the workpiece.

2 – Replacing ArcGlide parts

228940 – Breakaway retaining tether

To remove the breakaway retaining tether:

1. Remove the 2 screws from the slotted plate in the top of the breakaway.
2. Remove the slotted plate.
3. Remove the tether.

To replace the breakaway retaining tether:

1. Insert the new tether into hole of breakaway plate.
2. Reinstall the slotted plate and fasten the screws.
3. Insert the tether into the hole of the bracket mounted on the lifter and reattach the breakaway.
4. Use a level to verify that the torch is at a 90° angle to the workpiece.

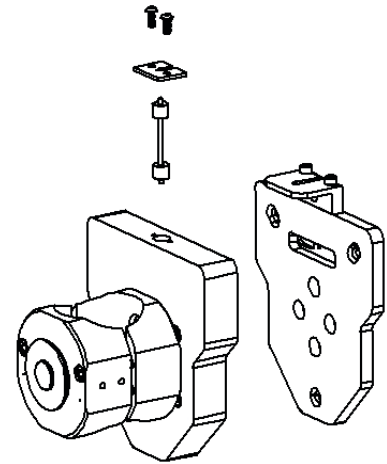

428081 – Servo amplifier module

Follow the steps in *Accessing control module parts* on page 12 to open the rear panel of the enclosure. Set aside all screws and other hardware for reuse.

To remove the servo amplifier module:

1. Remove the connector for the red and black wires to J11 on the processor board, inside the top of the enclosure.
2. Disconnect the white, in-line connector for the wires between the transformer and the power entry module.
3. Remove the connector from J3 on the THC control interface board.
4. Remove the ground wire from the ground screw on the back panel and set the back panel aside.
5. On the outside of the enclosure, remove the 2 screws from the outer ends of the heatsink.
6. Inside the enclosure, remove the 2 screws that hold the heatsink bracket to the servo amplifier module and lift the heatsink bracket out of the enclosure.
7. Remove any portion of the pink gasket that remains on the heatsink bracket.
8. Lift the servo amplifier board off the connectors on the control interface board.

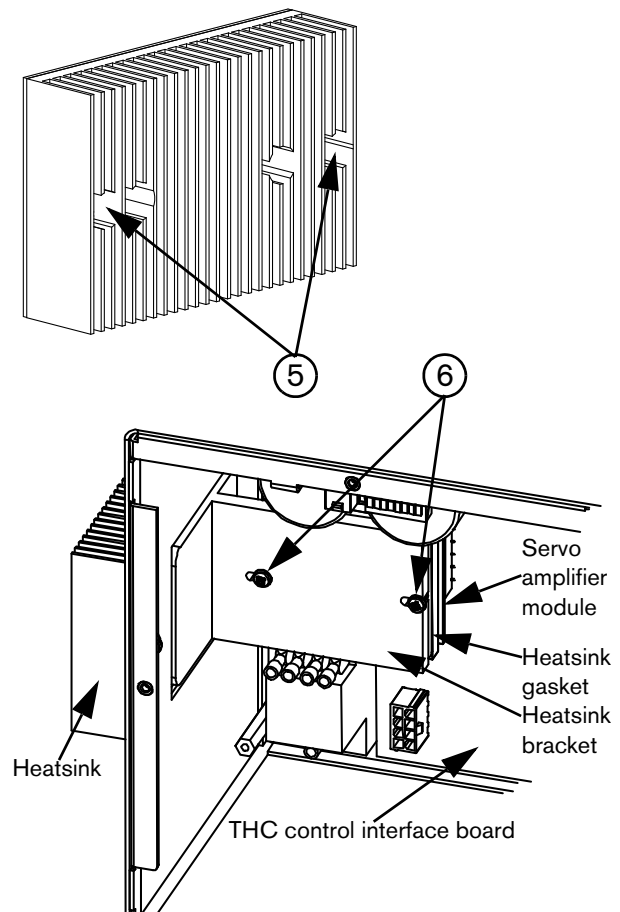

To replace the servo amplifier module:

1. Align the notch on the top of the servo amplifier assembly with the notch in the silk screen on the control interface board and align all the pins on the assembly with the connector on the control interface board.
2. Gently press the pins into the connector.
3. Carefully remove the two pieces of plastic film from the pink heatsink gasket and place it on top of the servo amplifier assembly. Align the notch and holes for screws on both ends.



Handle the heatsink gasket with care. It is made of fragile material.

4. Slide the heatsink bracket through the opening in the side of the enclosure. Verify that the bracket sits snugly on top of the servo amplifier assembly and gasket.
5. Insert screws into the top of the heatsink bracket but do not tighten them.
6. Fasten the screws through the outside of the heatsink into the enclosure. Tighten the screws to 2.25 N·m (20 lb·in.).
7. Inside the enclosure, tighten the screws in the heatsink bracket to 0.67 N·m (6 lb·in.).
8. Insert the connector for the red and black wires from the power supply into J11 on the processor board, inside the top of the enclosure.
9. Reconnect the two halves of the white, in-line connector for the wires between the transformer and the power entry module.
10. Insert the connector for wires from the transformer into J3 on the THC control interface board.
11. Reconnect the ground wire to the ground screw on the back panel.
12. Replace the back panel and fasten the screws. Tighten the screws to 1.13 N·m (10 lb·in.).

2 – Replacing ArcGlide parts

428241 – Lifter side shield

To remove the side shield:

1. Loosen the 4 screws along each side of the lifter slide.
2. Slide each side shield up so the screws are in the large part of the keyhole opening.
3. Lift each slide off the screws.

To replace the side shield:

1. Fit each side shield over the screws on each side of the slide and align the large part of the keyhole openings with each screw.
2. Slide each shield down so the screws lock in the top of each keyhole opening.
3. Tighten all the screws 1.13 N·m (10 lb·in.).

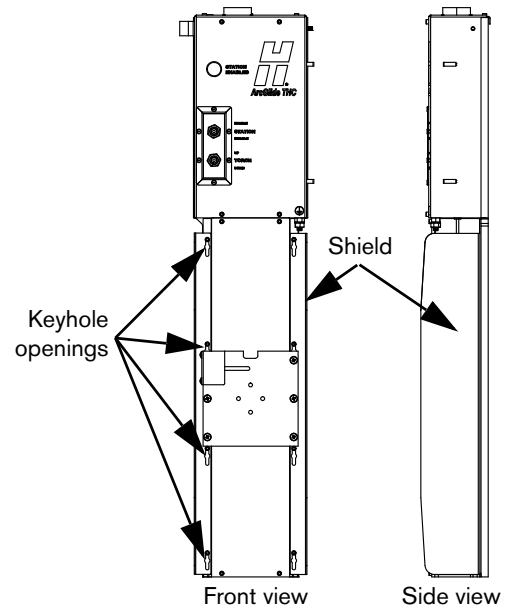

428242 – Ohmic wire

Follow the steps in *Accessing lifter parts* on page 12 to open the front cover of the motor enclosure. Set aside all screws and other hardware for reuse.

To remove the ohmic wire:

1. Unfasten the 3 screws on the top of the enclosure and set them aside. Remove the top of the enclosure.
2. Remove all cable connectors from the lifter interface board, except for the connector for the ohmic contact wire in J5.
3. Remove the bottom panel of the board assembly. This panel has Danger High-Voltage printed on the bottom side. Use needle-nose pliers to depress the tabs on the standoffs.
4. Disconnect the ohmic wire from terminal block J5 on the lifter interface board.
5. Cut the cable ties that secure the ohmic wire to the inside of the motor enclosure and remove the ohmic wire from the motor enclosure.
6. Disconnect the ohmic wire from the torch tip.

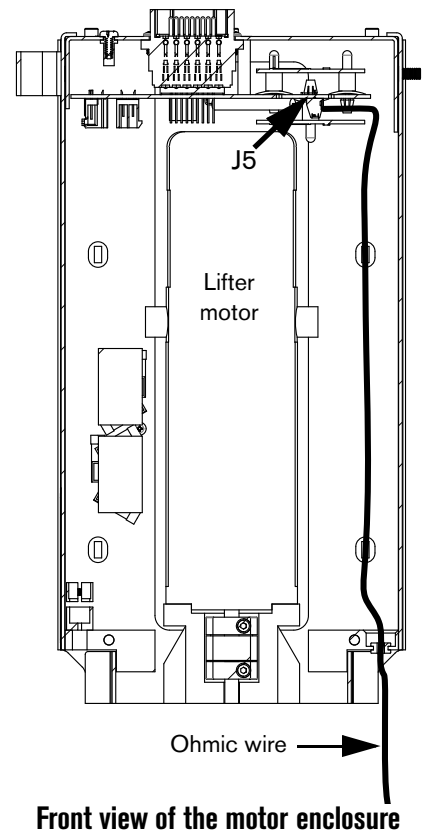

To replace the ohmic wire:

1. Insert the end of the ohmic wire through the hole in the bottom right of the motor enclosure.
2. Insert the ohmic wire into terminal block J5 on the underside of the lifter interface board.
3. Snap the bottom panel of the board assembly into place on the plastic standoffs.
4. Replace the top panel of the motor enclosure and fasten the 3 screws. Tighten the screws to 1.13 N·m (10 lb·in.).
5. Install cable connectors in the following connectors on the lifter interface board:

| | |
|----|---------------------|
| J1 | Upper limit switch |
| J3 | Lower limit switch |
| J4 | Breakaway |
| J6 | Motor brake encoder |
6. Use cable ties to fasten cables to the mounts on the inside back wall of the motor enclosure.
7. Connect the ohmic wire to the torch tip.
8. Install the connectors from the switches and LED on the front cover to the lifter interface board:

| | |
|----|-----------------------|
| J7 | Laser pointer |
| J8 | Enable/disable switch |
| J9 | Up/down switch |
9. Replace the front cover of the motor enclosure and fasten the 4 screws. Tighten the screws to 1.13 N·m (10 lb·in.).

2 – Replacing ArcGlide parts

428245 – Sealing band

To remove the sealing band:

1. Before you turn OFF power to the ArcGlide lifter, move the lifter carriage assembly to the vertical center of the slide.
2. Turn OFF power to the lifter.
3. Remove the 4 screws in the front cover of the slide and slide the cover down to remove it.
4. Remove the 4 screws for the 2 sealing band clamps at the top and bottom of the sealing band.
5. Remove the 4 screws from the sealing band guides, and use the tops of the guides to pull them from the top and bottom of the lifter carriage.
6. Slide the sealing band down through the lifter carriage to remove it.

To replace the sealing band:

1. Slide the new sealing band under the lifter carriage and pull it to the top of the slide.
2. Thread each end of the sealing band over the bottom, slanted edge of the sealing band guides.
3. Push the sealing band guides into place in the top and bottom of the lifter carriage.
4. Fasten the 4 screws in the sealing band guides to secure them to the lifter carriage. Tighten the screws to 1.30 N·m (11 lb·in.).
5. Replace the sealing band clamps over the top and bottom of the sealing band and fasten them to the slide with the 4 screws. Tighten the screws to 0.67 N·m (6 lb·in.).
6. Slide the front cover of the slide up from the bottom of the lifter and fasten it in place with the 4 screws. Tighten the screws to 1.13 N·m (10 lb·in.).

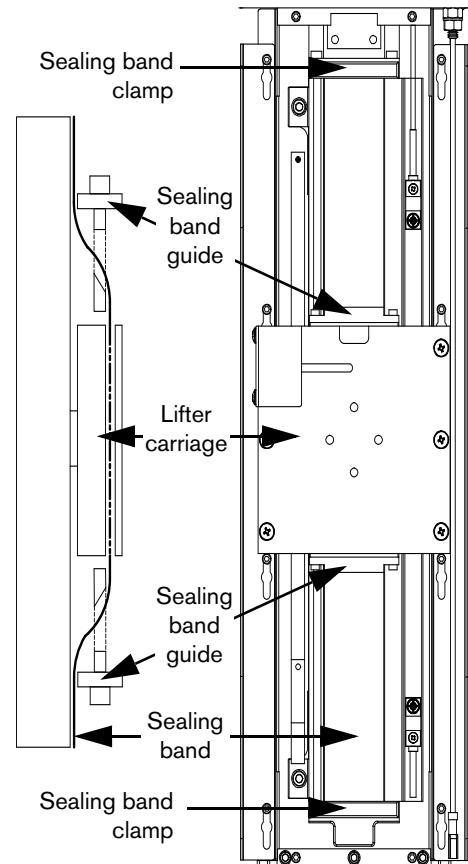

428302 – Lifter motor

The procedure to replace the lifter motor must be performed by trained technicians.

Improper assembly can result in binding and alignment problems with the proximity switches and the laser pointer.